

## Product Features

- Compliant with ITU-T G.691 STM-64 L-64.2
- Compliant to IEEE Std 802.3-2005 10Gb Ethernet 10GBASE-ZR/ZW
- XFP MSA Rev. 4.5 compliant
- Full digital diagnostic management interface
- XFP MSA package with duplex LC connector
- 1550nm EML Transmitter
- Up to 11.3Gb/s bi-directional data links
- Class 1 laser safety certified
- Operating temperature options
  - (Industrial) -40°C to +85°C
- Up to 80km on 9/125 μm SMF
- RoHS Compliant



## Applications

- SDH STM-64 L-64.2
- SONET OC-192 LR-2
- 80km 10G Ethernet 10GBASE-ZR/ZW
- 80km 10G Fiber Channel

## Descriptions

LX3004IDR XFP transceivers, according to 10 Gigabit Small Form Factor Pluggable Module Multi-Sourcing Agreement (XFP-MSA) INF-8077i Revision 4.5, are designed for serial optical data communications at 9.95 Gb/s to 11.3 Gb/s. They are compatible with SDH STM-64 L-64.2, 80km 10G Ethernet 10GBASE-ZR/ZW, 80km 10G Fiber Channel.

LX3004IDR is compliant with RoHS.

## Ordering Information

**Table 1. Ordering Information**

Part Number	Transmitter	Output Power	Receiver	Sensitivity	Reach	Temp	DDM	RoHS
LX3004IDR	1550nm EML	1 ~ +4dBm	APD	< -26dBm	80km	-40 ~ 85 °C	Available	Compliant

## Electrical Pin Description

**Table 2. Electrical Pin Description**

Pin	Logic	Symbol	Name/Description	Note
1	-	GND	Module Ground	1
2	-	V <sub>EE5</sub>	Optional -5.2V Power Supply - <b>Not Required</b>	-
3	LVTTL-I	Mod_DeSel	Module De-select; When held low allows module to respond to 2-wire serial interface	-

4	LVTTL-O	Interrupt	Interrupt; Indicates presence of an important condition which can be read over the 2-wire serial interface	2
5	LVTTL-I	TX_DIS	Transmitter Disable; Turns off transmitter laser output	-
6	-	V <sub>CC5</sub>	+5V Power Supply	-
7	-	GND	Module Ground	1
8	-	V <sub>CC3</sub>	+3.3V Power Supply	-
9	-	V <sub>CC3</sub>	+3.3V Power Supply	-
10	LVTTL-I/O	SCL	2-Wire Serial Interface Clock	2
11	LVTTL-I/O	SDA	2-Wire Serial Interface Data Line	2
12	LVTTL-O	Mod_Abs	Indicates Module is not present. Grounded in the Module	2
13	LVTTL-O	Mod_NR	Module Not Ready; Indicating Module Operational Fault	2
14	LVTTL-O	RX_LOS	Receiver Loss Of Signal Indicator	2
15	-	GND	Module Ground	1
16	-	GND	Module Ground	1
17	CML-O	RD-	Receiver Inverted Data Output	-
18	CML-O	RD+	Receiver Non-Inverted Data Output	-
19	-	GND	Module Ground	1
20	-	V <sub>CC2</sub>	+1.8V Power Supply - <b>Not Required</b>	-
21	LVTTL-I	P_Down/RST	Power down; When high, requires the module to limit power consumption to 1.5W or below. 2-Wire serial interface must be functional in the low power mode. Reset; The falling edge initiates a complete reset of the module including the 2-wire serial interface, equivalent to a power cycle.	-
22	-	V <sub>CC2</sub>	+1.8V Power Supply - <b>Not Required</b>	-
23	-	GND	Module Ground	1
24	PECL-I	RefCLK+	Reference Clock Non-Inverted Input, AC coupled on the host board - <b>Not Required</b>	3
25	PECL-I	RefCLK-	Reference Clock Inverted Input, AC coupled on the host board - <b>Not Required</b>	3
26	-	GND	Module Ground	1
27	-	GND	Module Ground	1
28	CML-I	TD-	Transmitter Inverted Data Input	-
29	CML-I	TD+	Transmitter Non-Inverted Data Input	-
30	-	GND	Module Ground	1

**Notes:**

1. Module ground pins Gnd are isolated from the module case.
2. Shall be pulled up with 4.7KΩ to 10KΩ to a voltage between 3.15V and 3.45V on the host board.
3. Reference Clock is not required. If present, it will be ignored.

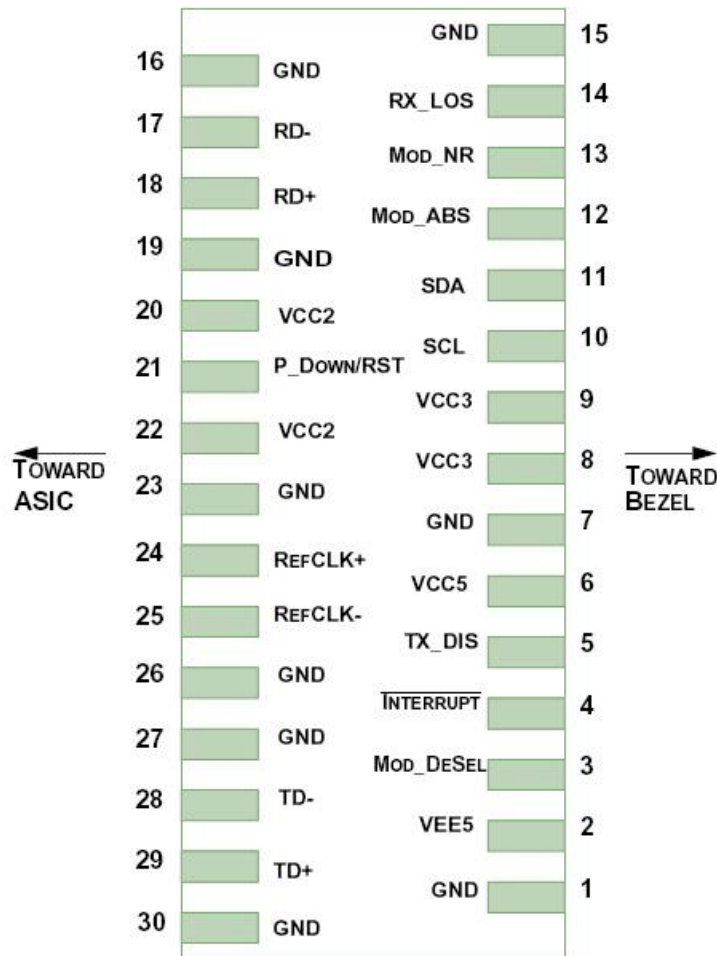

Figure 1. Host PCB XFP Pinout Top View

## Absolute Maximum Ratings

Stresses in excess of the absolute maximum ratings can cause permanent damage to the device. These are absolute stress ratings only. Functional operation of the device is not implied at these or any other conditions in excess of those given in the operational sections of the data sheet. Exposure to absolute maximum ratings for extended periods can adversely affect device reliability.

Table 3. Absolute Maximum Ratings

Parameter	Symbol	Minimum	Maximum	Unit
Storage Temperature	T <sub>s</sub>	-40	85	°C
Relative Humidity	RH	5	95	%
Supply Voltage	V <sub>CC3</sub>	-0.5	4.0	V
Supply Voltage	V <sub>CC5</sub>	-0.5	6.0	V

## Recommended Operating Conditions

Table 4. Recommended Operating Conditions

Parameter	Symbol	Min	Typ	Max	Unit
Operating Case Temperature (Commercial )	T <sub>C</sub>	-40	-	80	°C
Supply Voltage	V <sub>CC3</sub>	3.135	3.3	3.465	V
Supply Voltage	V <sub>CC5</sub>	4.75	5.00	5.25	V
Data Rate	-	9.95	-	11.3	Gb/s

## Transceiver Electrical Characteristics

**Table 5. Transceiver Electrical Characteristics**

Parameter	Symbol	Minimum	Typical	Maximum	Unit	Notes
Supply Current	I <sub>CC3</sub>	-	-	750	mA	-
Supply Current	I <sub>CC5</sub>	-	-	500	mA	-
Power Dissipation	P <sub>D</sub>	-	-	3500	mW	-
<b>Transmitter</b>						
Input Differential Impedance	Z <sub>IN</sub>	-	100	-	Ω	-
Differential Data Input Swing	V <sub>IN, P-P</sub>	120	-	1000	mV <sub>P-P</sub>	-
Tx_Disable, P_Down/RST	V <sub>IH</sub>	2.0	-	V <sub>CC3</sub> +0.3	V	-
	V <sub>IL</sub>	-0.3	-	0.8	V	-
Transmit Disable Assert Time	-	-	-	10	us	-
<b>Receiver</b>						
Output Differential Impedance	Z <sub>O</sub>	-	100	-	Ω	-
Differential Data Output Swing	V <sub>OUT, P-P</sub>	340	-	850	mV <sub>P-P</sub>	1
Data Output Rise Time, Fall Time	t <sub>r</sub> , t <sub>f</sub>	24	-	-	ps	2
Rx_LOS, Mod_NR, Interrupt	V <sub>OH</sub>	V <sub>CCHOST</sub> -0.5	-	V <sub>CCHOST</sub> +0.3	V	3
	V <sub>OL</sub>	0	-	0.4	V	3

**Notes:**

- Internally AC coupled, but requires a external 100Ω differential termination.
- 20 – 80 %.
- Loss Of Signal is an open collector output. Should be pulled up with a 4.7kΩ-10kΩ resistor on the host board.

## Transmitter Optical Characteristics

**Table 6. Transmitter Optical Characteristics**

Parameter	Symbol	Minimum	Typical	Maximum	Unit	Notes
Launch Average Optical Power	P <sub>o</sub>	1	-	+4	dBm	1
Center Wavelength Range	λ <sub>c</sub>	1530	1550	1565	nm	-
Extinction Ratio	EX	9	-	-	dB	2
Spectral Width (-20dB)	Δλ	-	-	1	nm	-
Side Mode Suppression Ratio	SMSR	30	-	-	dB	-
Dispersion Penalty @ 1600ps/nm	DP	-	-	3	dB	2

Average Optical Power (Laser Off)	P <sub>OFF</sub>	-	-	-30	dBm	1
Eye Diagram	ITU-T G.691 SDH STM S-64.2b compatible					2

**Notes:**

1. The optical power is launched into 9/125 μm SMF.
2. Measured with a PRBS 2<sup>31</sup>-1 test pattern @ 9.953Gb/s.

## Receiver Optical Characteristics

**Table 7. Receiver Optical Characteristics**

Parameter	Symbol	Minimum	Typical	Maximum	Unit	Notes
Center Wavelength	λ <sub>c</sub>	1270	-	1620	nm	-
Receiver Sensitivity (P <sub>avg</sub> )	S	-	-	-26	dBm	1
Receiver Overload (P <sub>avg</sub> )	P <sub>OL</sub>	-7.0	-	-	dBm	1
Optical Return Loss	ORL	27	-	-	dB	-
LOS De-Assert	LOS <sub>D</sub>	-	-	-27	dBm	-
LOS Assert	LOS <sub>A</sub>	-38	-	-	dBm	-
LOS Hysteresis	-	0.5	-	-	dB	-

**Notes:**

1. Measured with worst ER; 1550nm; PRBS 2<sup>31</sup>-1 test pattern, BER<10<sup>-12</sup>.

## Recommended Host Board Power Supply Filter Network

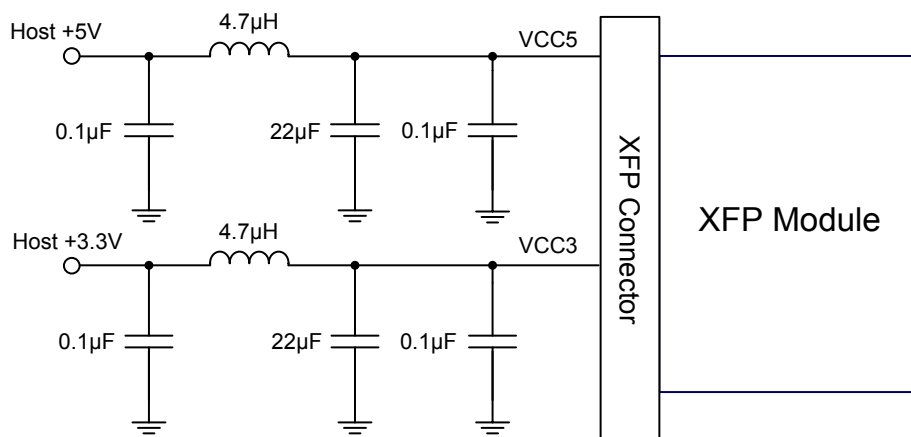

Figure 2. Recommended Host Board Power Supply Filter Network

## Recommended Application Interface Block Diagram

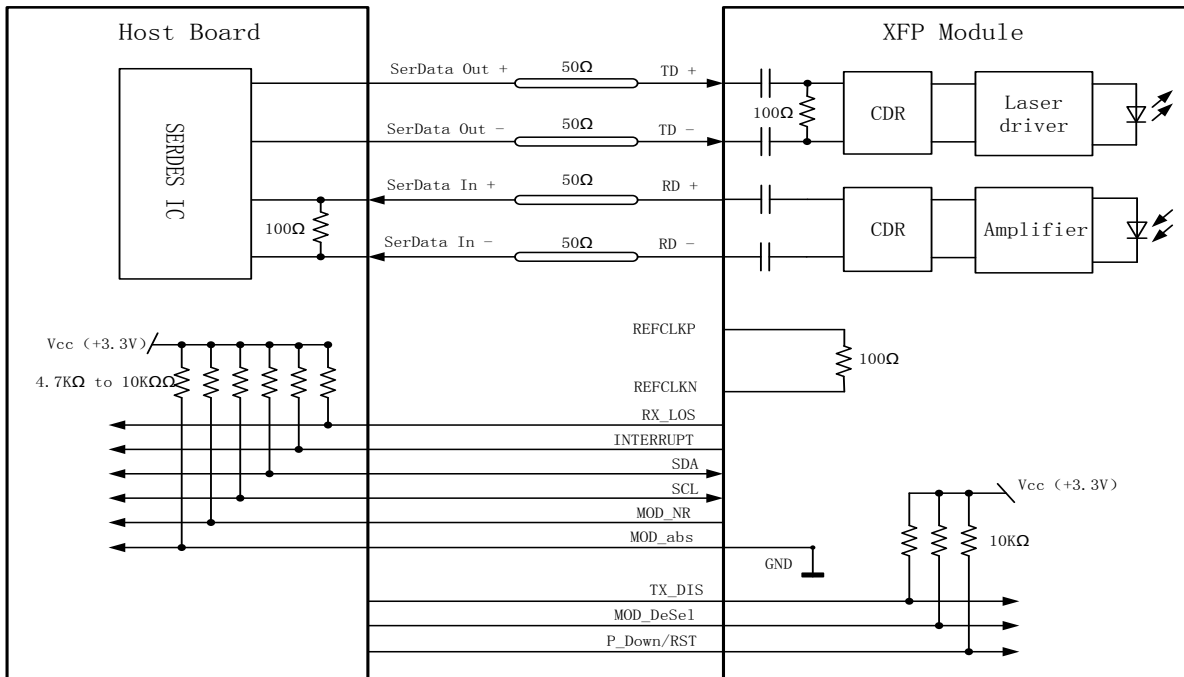

Figure 3. Recommended Application Interface Block Diagram

## Mechanical specifications

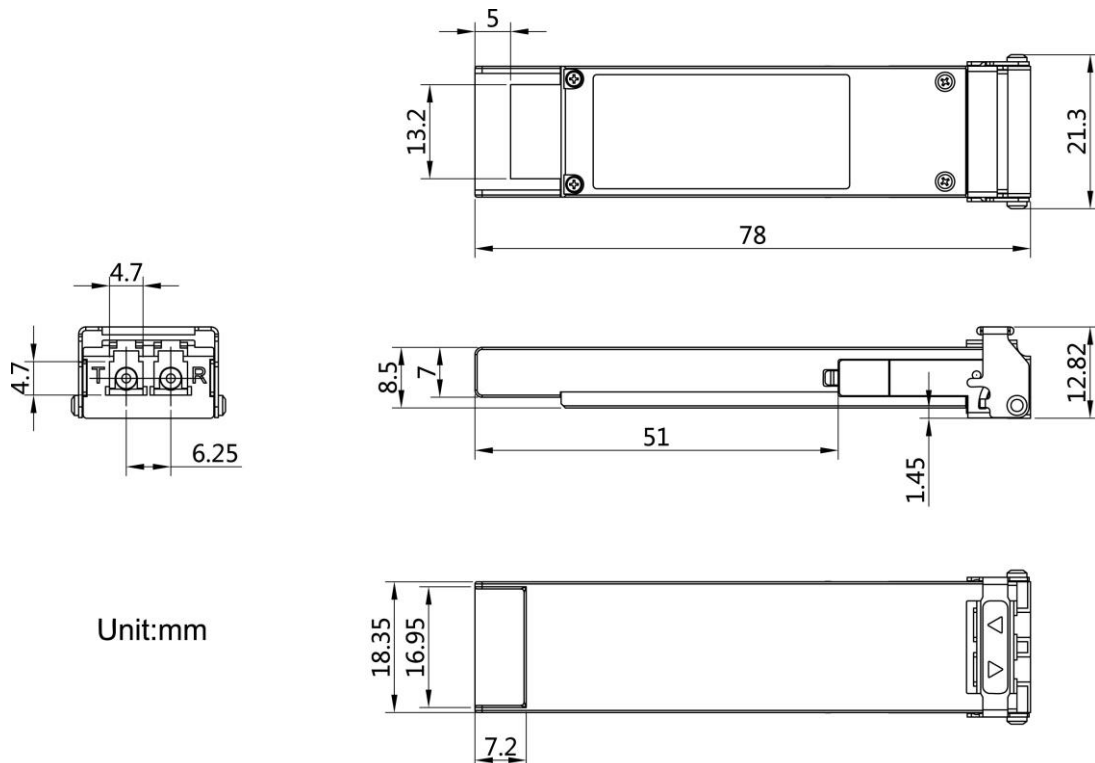

Figure 4. Outline Drawing

---

## Revision History

<b>Date</b>	<b>Rev</b>	<b>Description</b>	<b>Modified By</b>
10/10/2009	V1.0	Preliminary Release	Heling Guan

## **For More Information**

### **Linktel Technologies Co., Ltd**

info@linkteltech.com

www.linkteltech.com

### **Linktel USA**

1601 McCarthy Blvd #9, Milpitas, CA 95035, USA

Tel: +1 408 807 0482

Email: [linktelus@linkteltech.com](mailto:linktelus@linkteltech.com)

[jimli@linkteltech.com](mailto:jimli@linkteltech.com)

### **Linktel International (Except USA)**

E12, No. 52 Liufang Road, East-Lake Hi-tech Development Zone, Wuhan, China

Tel: +86 27 8792 9207

Email: [ailsagong@linkteltech.com](mailto:ailsagong@linkteltech.com)

### **Linktel China**

E12, No. 52 Liufang Road, East-Lake Hi-tech Development Zone, Wuhan, China

Tel: +86 27 8792 9213

Email: [lifan@linkteltech.com](mailto:lifan@linkteltech.com)